

80BRE80

BRASIERA RIBALTABILE ELETTRICA, VASCA FERRO-INOX DA 86 LT.

ELECTRIC TILTING BRATT PAN, IRON-STEEL TANK 86 LT.

Caratteristiche  
Features



Struttura esterna e coperchio in acciaio inox AISI 304 | Coperchio incernierato posteriormente e bilanciato a molla | Ribaltamento manuale della vasca ottenuto mediante volantino in materiale termostatico e vite senza fine | Vasca con pareti in acciaio inox AISI 304 e fondo in ferro di grosso spessore | Rubinetto carico acqua | Resistenze corazzate INCOLOY a diretto contatto del fondo esterno termodiffusore della vasca | Regolazione termostatica della temperatura da 50° a 300°C | Termostato di sicurezza a riarmo manuale | Scarico fumo in ghisa rimovibile | Piedini in acciaio inox regolabili in altezza

External structure and lid in AISI 304 stainless steel | Lid hinged at the back and counter-balanced with a spring | Manual tipping of the tank by means of hand wheel in thermoplastic material and self-tapping screw | Tank with walls in AISI 304 stainless steel and bottom in iron | Water-filling tap | INCOLOY armoured heating elements in direct contact with the heat-radiating external bottom of the tank | Thermostatic regulation of the temperature from 50° to 300°C | Safety thermostat with manual reset | Removable vitrified cast iron exhaust grate | Adjustable AISI 304 stainless steel feet



MODELLO  
MODEL



DIMENSIONI mm  
DIMENSIONS mm



POTENZA ELETTRICA KW  
ELECTRIC POWER KW



VOLUME m<sup>3</sup>



PESO Kg  
WEIGHT Kg



ALIMENTAZIONE  
FEEDING



ALLACC. ELETTRICO  
ELEC. CONNECTION

80BRE80

800x900x900

9,9

1,2

190

400 V

VAC400-3N 50/60Hz

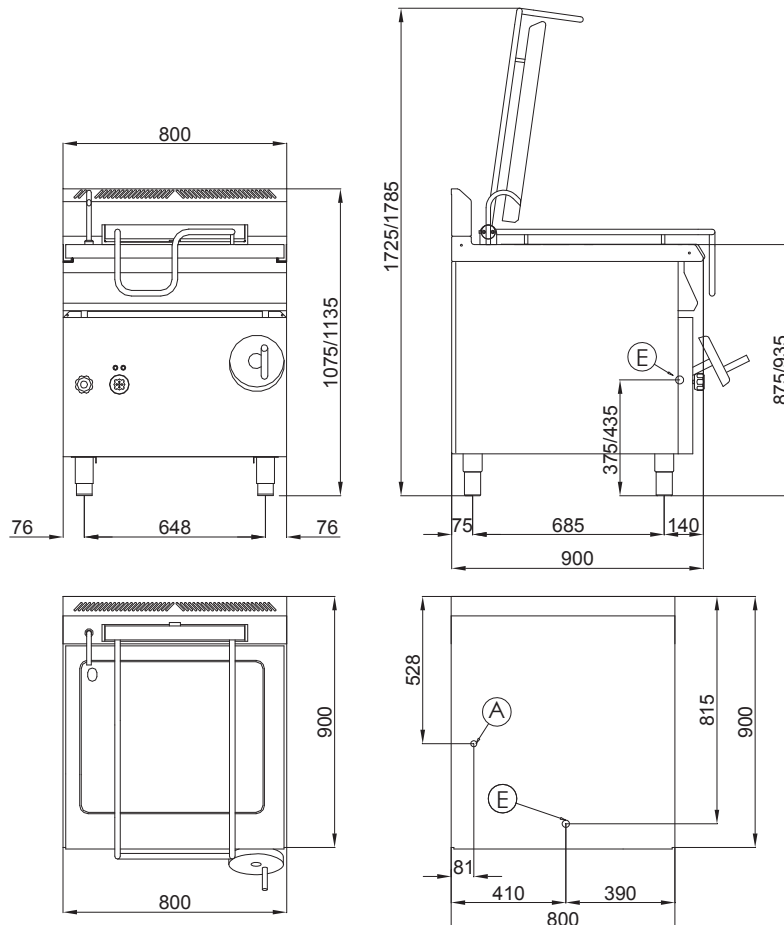

A = Carico acqua ø 12 mm  
Water supply ø 12 mm

E = Allacciamento elettrico  
Electrical connection