

80TFGL(400)

FRY-TOP A GAS TOP

TOP GAS FRY-TOP

Caratteristiche Features



| Piastra di cottura realizzata in speciale acciaio levigato di grosso spessore | Paraspruzzi perimetrale 30/10 in acciaio inox AISI 304 saldato ermeticamente | Cassetto raccogli grassi estraibile | Bruciatori in acciaio inox a fiamma stabilizzata | Regolazione della temperatura da 100° a 300°C mediante rubinetto termostato con sicurezza e termocoppia | Accensione piezoelettrica del pilota | Pannello comandi facilmente estraibile per facilitare le operazioni di pulizia e manutenzione | Scarico fumo in ghisa rimovibile

| Cooking plate in special thick honed steel | 30/10 perimeter splashguard in ISI 304 hermetically welded stainless steel | Removable fat collecting drawer | Burners in stainless steel with stabilized flame | Temperature regulation from 100°C to 300°C by means of thermostatic tap with safety valve and thermocouple | Piezoelectric pilot ignition | Control panel which can be quickly removed for easy cleaning and maintenance | Removable vitrified cast iron exhaust grate



MODELLO
MODEL



DIMENSIONI mm
DIMENSIONS mm



POTENZA GAS KW
GAS POWER KW



VOLUME m³



PESO Kg
WEIGHT Kg



ALLACCIAMENTO GAS
GAS CONNECTION

80TFGL(400)

400x900x290

8

0,3

84

Ø 1/2"

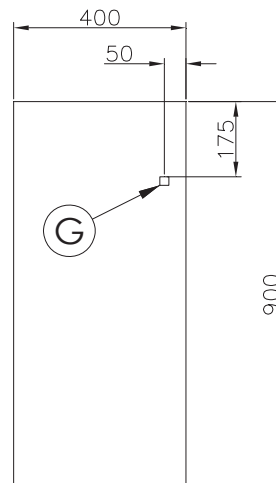
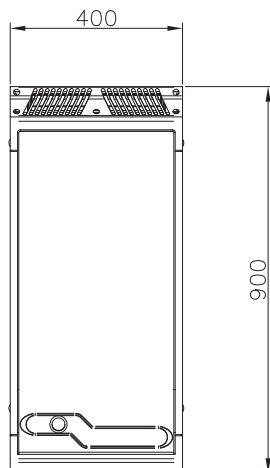
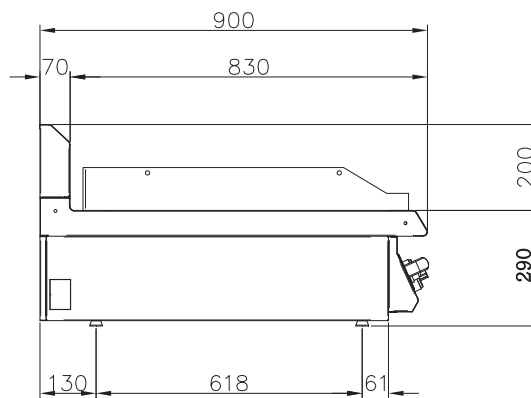
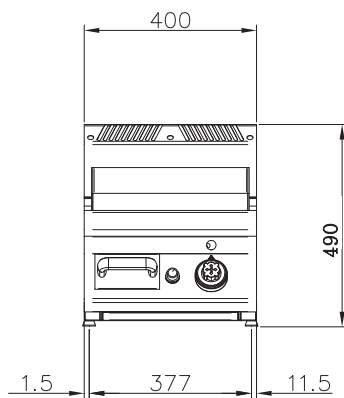

G = Gas Ø 1/2"